

3P Volume Filter VF2, VF3, VF6

Rainwater filters for installation within manhole chambers

Operating and assembly instructions

- ❑ Item No. 1000700 Volume Filter VF2
- ❑ Item No. 1000800 Volume Filter VF3
- ❑ Item No. 1000900 Volume Filter VF6



Content:

Technical data 02
 How it works..... 04
 Usage..... 04
 Installation guide 05
 Installation advice, Optimal installation situation, Cleaning the filter..... 06
 Removal of lamella unit, Maintenance advice, Guarantee 07

VF2: For roof areas up to 1347 m². Rainwater inlet diameter at 200 mm. outlet to storage tank at 150 mm. Sewer connection in the manhole at 200 mm diameter. Height difference between rainwater inlet and outlet to tank just 32 cm. Filter insert easily removed for cleaning. Maximum flow rate of 25.5 l/s.

VF3: For roof areas up to 1347 m². 2 No. Rainwater inlets at diameter 200 mm. Outlet to storage tank at 150 mm. Sewer connection in the manhole at 200 mm diameter. Height difference between rainwater inlet and outlet to tank just 32 cm. Lamella unit with integral fine filter easily removed for cleaning. Maximum flow rate of 33 l/s. The 3P Volume Filter VF3 can be easily converted into the 3P Volume Filter VF4.

VF6: For roof areas up to 2433 m². 2 No. Rainwater inlets at diameter 250 mm. Outlet to storage tank at 200 mm. Sewer connection is to be provided in the manhole at a diameter of OD 250 mm. Height difference between rainwater inlet and outlet to tank just 32 cm. Lamella unit with integral fine filter easily removed for cleaning. Maximum flow rate of 70.5 l/s.

Please read all the following information, which contains important instructions for the use and maintenance of the 3P Volumefilters VF2 - VF6.



Technical data:

Rainwater filters for installation within manhole chambers

Sideview

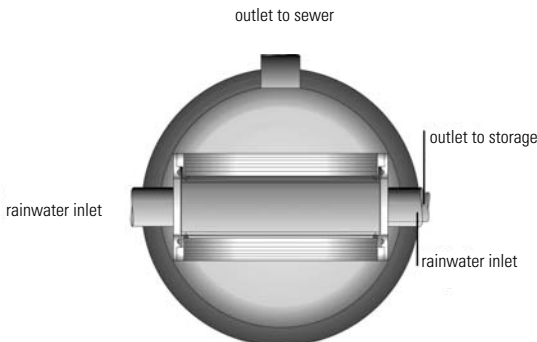

Overview

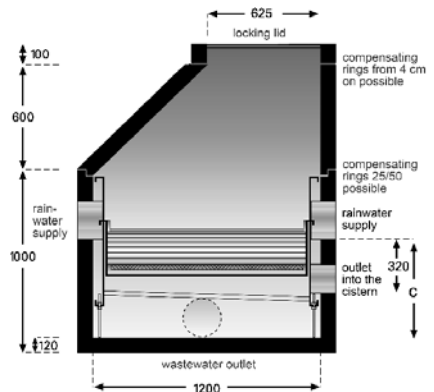

Operating and assembly instructions

Volume Filter VF2, VF3, VF6

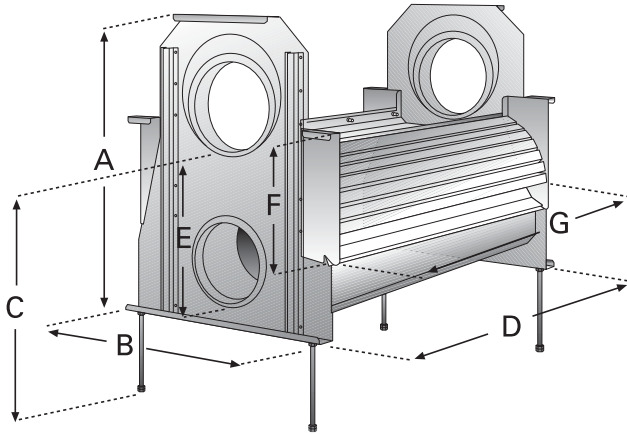

| Filter | Rainwater outlet | Outlet to sewer | Inlet to storage tank | A in mm | B in mm | C in mm | D in mm | E in mm | F in mm | G in mm | Mesh size sieve in mm | min. Ø man-hole | max. flow rate*** | connectable area |
|--------|------------------|-----------------|-----------------------|---------|---------|---------|---------|---------|---------|---------|-----------------------|-----------------|-------------------|---------------------|
| VF2 | 1 x DN 200 | 1 x DN 200 | 1 x DN 150 | 670 | 540 | 520 | 390 | 320 | 275 | 320 | 0.390 / 0.980 | 1000 | 25,5 l/s | 1347 m ² |
| VF3 | 2 x DN 200* | 1 x DN 200 | 1 x DN 150 | 670 | 540 | 520 | 980 | 320 | 275 | 880 | 0.390 / 0.980 | 1200 | 33,0 l/s | 1347 m ² |
| VF6 | 2 x DN 250** | 1 x DN 250 | 1 x DN 200 | 670 | 540 | 520 | 980 | 320 | 275 | 880 | 0.390 / 0.980 | 1200 | 70,5 l/s | 2433 m ² |

* VF3 has a filter unit only on one side

** You don't need to use both inlets but filter capacity will be higher

*** The max. flow rate defines, how much water can pass through the filter in case of a totally polluted filter.

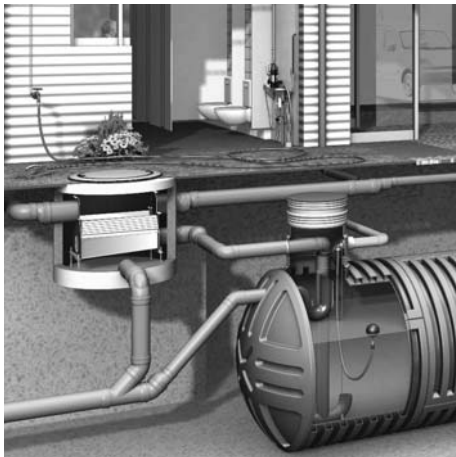

installation of a volume filter within manhole chambers



installation of a volume filter within manhole chambers

Operating and assembly instructions

Volume Filter VF2, VF3, VF6

How it works:

1. As rain water arrives the water level builds up, and overtops the filter lip, so ensuring it is distributed evenly across the whole width of the filter cascade.
2. Pre-cleaning through the cascades. Larger dirt particles are washed across the cascades directly to the sewer.
3. Pre-filtered water then flows over the secondary filter (mesh size 0.55 mm). Due to the special structure of the sieve mesh, any dirt is washed directly into the sewer which means the filter is self cleaning, low maintenance.
4. Cleaned water flows to the storage tank.
5. Dirt goes to the sewer.

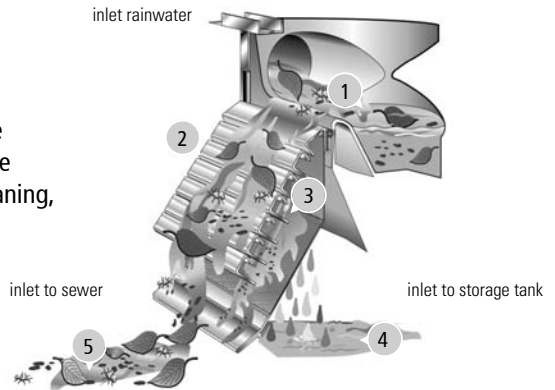

Usage:

3P Volume Filter VF2, VF3 und VF6 for larger roof areas.

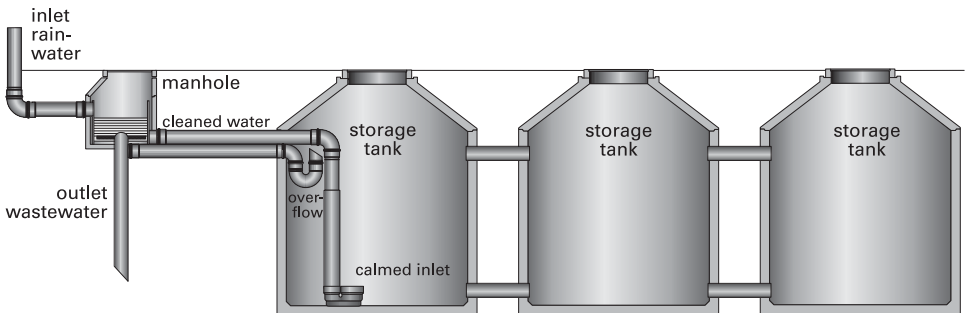

Operating and assembly instructions

Volume Filter VF2, VF3, VF6

Installation:

We recommend installing the filter in its working position. From experience in the "real world" we recommend use of short connection pipe lengths to any manhole chamber, pushed in from the outside through the chamber wall inlets into the corresponding connections of the filter. This will help to minimise the risk of the connecting pipes or the seals being displaced during the subsequent construction process. (settlement etc.)

When connected directly at the building site please make sure that all seals are set correctly. The pipes should not project into the filter more than 5 cm.

The filter should be installed perpendicular and horizontal. There are adjustable feet to accommodate small height differences. The manhole itself should be set level. The manhole chamber base should ideally have a gradient of approximately 5% or more towards the sewer outlet. This ensures any sediment is more easily rinsed away. We strongly recommend that the distance between the manhole floor and the lower sump in the filter should be at least as big as the filter inlet diameter. You can adjust this distance with the help of the adjustable feet (the threaded bars). You may wish to have your installer/drainage contractor prepare the manhole chamber according to the following conditions. The diameter of the chamber wall orifices will depend on the selected seals for the pipes.

Outlet to waste:

Base of outlet pipe = base of manhole

Inlet to storage tank:

Base of the inlet pipe = 20/25 cm above floor of manhole chamber

2 x inlets rainwater:

Invert of 2 No inlet pipes = 32 cm

from invert of pipe outlet to storage tank, which is therefore 57/62 cm from base (floor) of chamber.

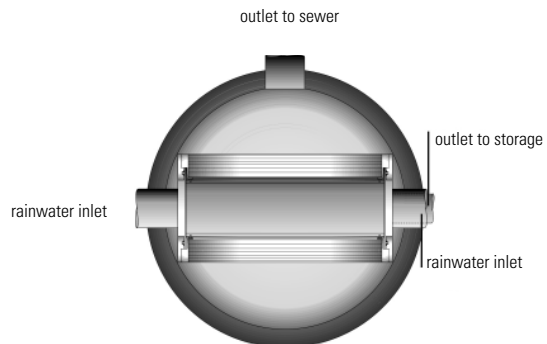

Operating and assembly instructions

Volume Filter VF2, VF3, VF6

Installation advice:

We recommend you remove the filter mesh unit(s) before installation. Install the 4 threaded bolt feet, length c. 25 cm, and lower the filter into the manhole. Now push the connection pipe (and seals) through the manhole wall into the corresponding sealing rings of the filter. Small height differences are then further adjustable using the adjustable feet (threaded bolts). Check, with a spirit level, that water will be level in the filter's receiving sump for optimal performance. Replace the lamella filter mesh unit(s) once construction is complete. We also recommend covering the filter during installation to keep it clean (during any setting of concrete rings and lid etc.)

Optimal installation situation:

By pass and inlet feed to both sides of filter. High security due to bypass installation, because of this you can connect to larger roof areas. Higher efficiency through inlet feed from both sides of filter.

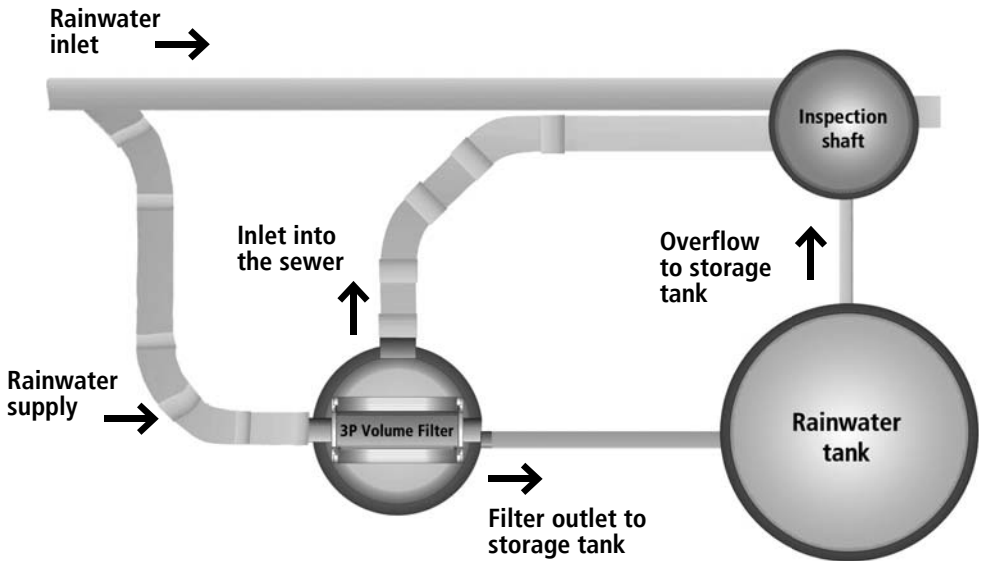

Cleaning the filter:

Monitor the Volume Filter VF2, VF3 and VF6 regularly, clean if necessary

Operating and assembly instructions

Volume Filter VF2, VF3, VF6

Removal of lamella unit:

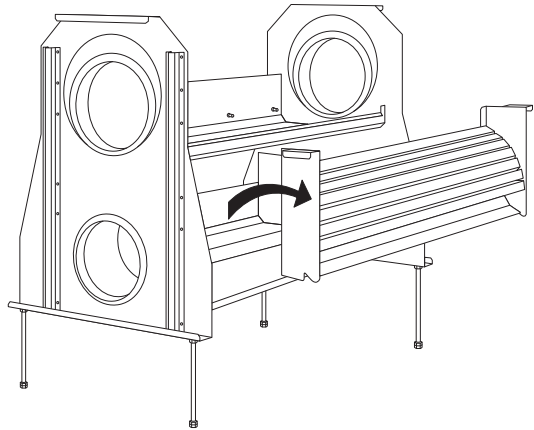

Maintenance advice:

Once a year flush out the sump and manhole with a hose. The sump can be emptied through a little orifice in the sump floor. Therefore the inlet to the tank should be sealed temporarily.

The lamella unit can be cleaned with a high pressure cleaner, but take care not to hold any lance too close to the delicate mesh, lest it damage the mesh itself.

Guarantee:

3P Technik Filtersysteme GmbH offers this product the guarantee required by law (from date of purchase).



3P Technik Filtersysteme GmbH

Öschstraße 14

73072 Donzdorf - Germany

T +49 (0) 71 62 - 94 60 7-0

F +49 (0) 71 62 - 94 60 7-99

info@3ptechnik.de

www.3ptechnik.com