

Description:

Provides a calmed inlet for rainwater in larger rainwater tanks.

Dirt particles denser than water sink to the bottom of a rainwater tank and form a sediment layer, which demonstrably has a positive influence on the stored rainwater. Rainwater tanks with a sediment layer do have clearer water. The Giant Calmed Inlet prevents the incoming rainwater from disturbing this settled sediment layer, keeping the water free of dirt particles. The Giant Calmed Inlet also supplies the lower water layers within the tank with oxygen so that it remains fresh.

Ideal for the use in large-scale installations. It is suitable for DN 150 / DN 250 plastic pipe.



How it works:

1. Rainwater is led through the calmed inlet into the tank
2. As it flows through the calmed inlet the velocity of the water slows down substantially and enters the rainwater tank with no turbulences, the sediment layer is not being disturbed.
3. The calmed rainwater supplies more oxygen to the rainwater in the lower parts of the tank, therefore keeping the water fresh by preventing anaerobic decomposition

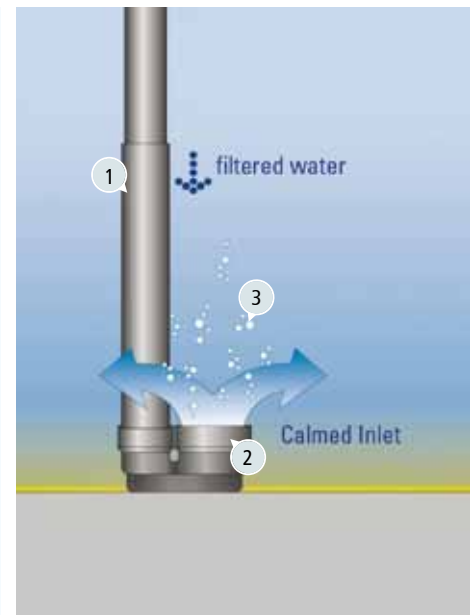

Technical Data:

Connection: DN 150 / DN 250

Material: Polyethylene

Weight: 6 kg

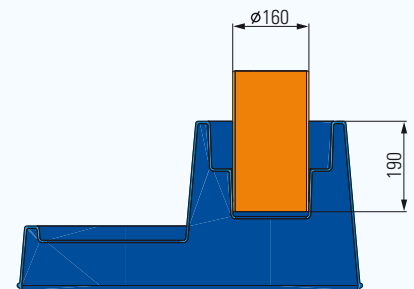
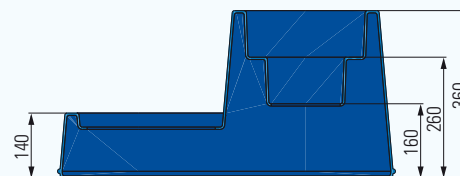
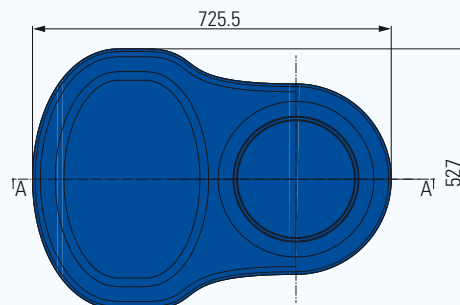

Example:

Connecting a DN 150 / DN 250 plastic pipe
DN 150 / DN 250

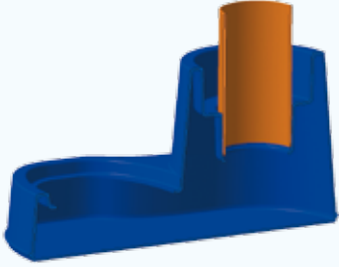

Text for invitation of tenders:

Pos.	Quantity	Article	Price in €
1.1	_____	3P Giant Calmed Inlet DN 150 / DN 250 Giant Calmed Inlet for installation in larger rainwater tanks Prevents disturbance to the sediment layer in the tank	_____

Packing unit
3P Giant Calmed Inlet DN 150 / DN 250:
m³-box: 8 pieces
Pallet: 16 pieces