

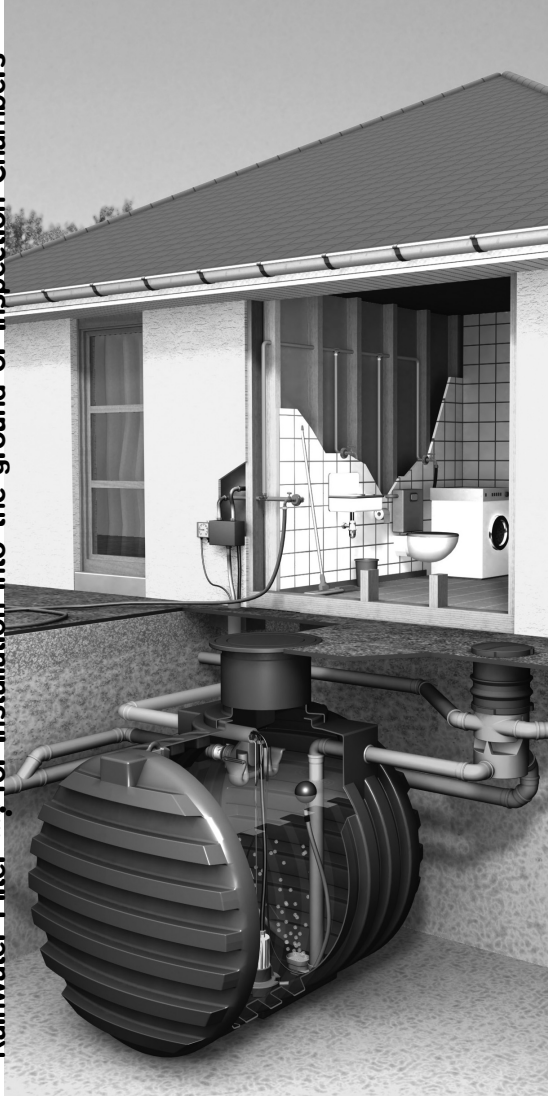

3P Volume Filter VF1

Rainwater Filter ... for Installation into the ground or Inspection Chambers



Installation and Maintenance Instruction



www.3PTechnik.com.au

From our rainwater product range:



Thank you for selecting an 3P filter. This filter has been designed to provide years of trouble free service. Please familiarize yourself with these instruction to ensure correct and reliable operation.

1. Technical data

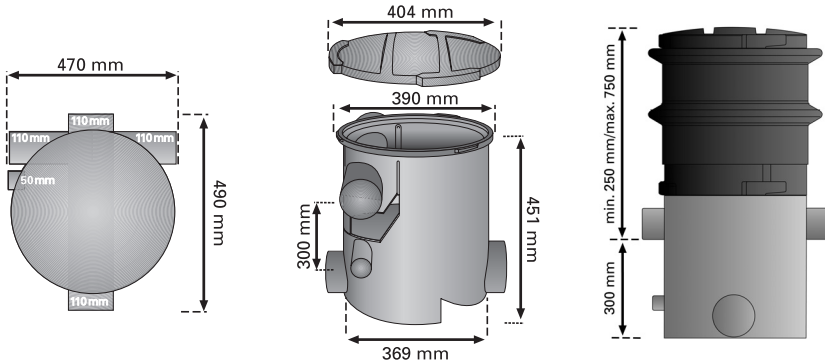

2. How it works

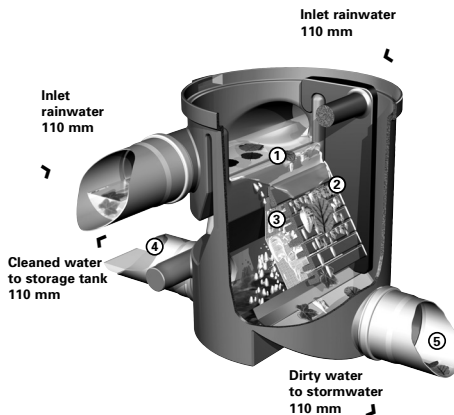

- ① As water arrives the level builds up and is equally distributed across the cascade
- ② Pre cleaning through the cascades. Largest dirt particles are led across the primary filter cascades directly to the stormwater.
- ③ Pre filtered water then flows over the secondary filter sieve (mesh size 0,65 mm). Due to the special mesh structure of the sieve, any dirt washes directly into the stormwater. Very low maintenance.
- ④ Cleaned water flows to storage.
- ⑤ Dirt goes to the stormwater.



Pedestrian Traffic Loading

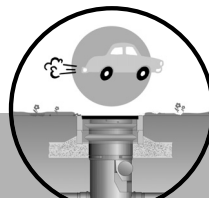

Vehicle Traffic Loading

Vehicle Traffic Loading

Where vehicle loading is required the filter should be installed beneath a suitable cover to an appropriate highway specification.

Pedestrian Traffic Loading

For pedestrian loading only, the standard filter lid is suitable.

3. Installation advice

Installation direct in ground

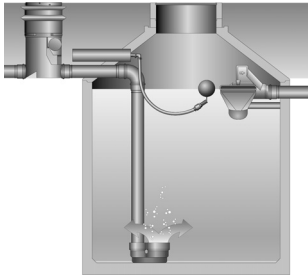

Installation in an inspection chamber

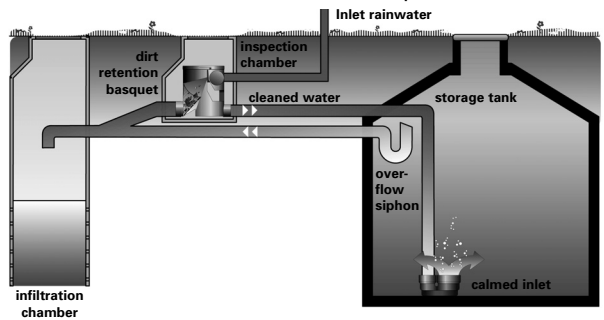

4. Installation

3P Volume Filter

- Connections to the 3P Volumefilter VF1 can be made with universal connectors.
- Rainwater enters through the upper Inlets, at 110 mm. For roof areas up to 150 m² connect from either right or left.
- For roof areas above 150 m² connecting on both sides
- Saw off 1 cm from the outside of the selected Inlet(s).
- Cleaned water is led via the outlet ④ at 110 mm to the storage tank.
- Dirty water goes via the outlet ⑤ at 110 mm to waste.
- Install the 3P Volumefilter VF1 horizontally on a level stable surface. For deeper installations the 3P Telescopic Extension can be used to reach ground level.



Installation of the Telescopic Extension

- Lift the lid off the 3P VF1 and lock the lower part of the 3P Telescopic Extension tube, using the bayonet socket fitting, onto the 3P Volumefilter VF1. It has to be fully engaged.
- The upper surface of the upper ring collar to the upper section of the Telescopic Tube can be fitted flush at ground level. This leaves the VF1 lid just proud of the ground surface for easy removal and access.
- Push the upper section of the 3P Telescopic Extension on to the lower part until you reach the required height.
- If the final required height is lower than the minimum with the two pieces, simply cut by sawing the upper or the lower part with a fret saw to the required height.
- If the final required height is higher than the maximum you can use a second Telescopic Extension on top.
- Next, back fill the tube surround with gravel or stone chippings. Compress the back fill below the upper collar of the upper extension section, so that the collars take the loading, and not the VF1 below.
- If installed in a block built inspection chamber there may be no need for the Telescopic Extension Tube, or it can be fitted to the base of an inspection chamber floor.



5. Maintenance advice

The filter requires cleaning regularly. If it is not raining unscrew the lid of the housing and clean with a water jet the tray and the filter element. Then remove the filter element. Using a 3 mm Allen key undo the screws retaining the filter mesh. Rinse the filter mesh with water. Clean with mild detergent and a stiff brush, both sites to help dissolve any fatty deposits or hydrocarbon build up. Rinse it again. Do not use a metal brush which may damage the filter mesh. You may also put the filter mesh into a dishwasher. After cleaning examine the filter by holding up against the light and inspect for any blocked holes in the filter mesh. If the filter is clean put the filter mesh back and fixed it with the screws.

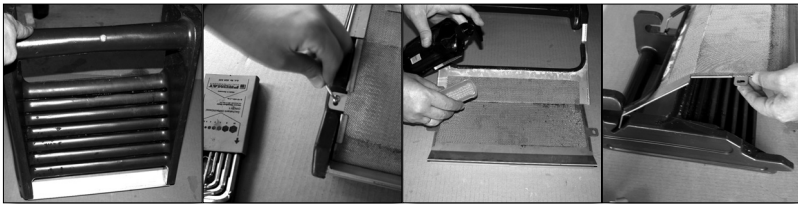

Insert the filter element into the housing.

6. Accessories

3P Removal Handle



3P Removal Handle
Art.-Nr. 1000550
Ideal for removal
of the 3P Filters
from deeper installations.
Remains in position.
Length: 500 mm.

3P Telescopic Extension



3P Telescopic Extension
Art.-Nr. 1000560
Plastic telescopic shaft
for installation directly
into the ground.
Material: Polyethylene.

7. Guarantee

3P Technik Australia Pty. Ltd. offers this product the guarantee of two years (from date of purchase).

info@3PTechnik.com.au

www.3PTechnik.com.au